

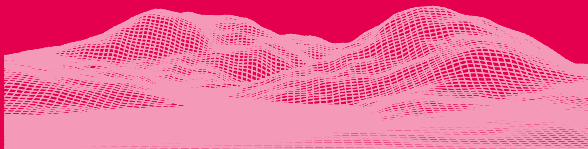

SONIC
MIGHTY

8K



Dear User,

Thank you for joining us. Please read the Sonic Mighty 8K manual thoroughly and follow the instructions step-by-step to get the best printing experience.

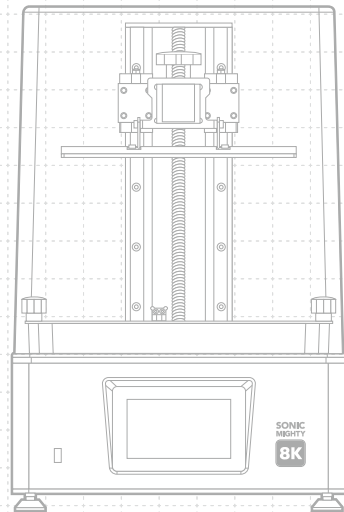



Please scan the QR code for Sonic
Mighty 8K user manual in other
languages.

03	01 Before You Start
04	02 Introduction
06	03 Prepare Your 3D Printer
	Guided Process for Initial Use
	Hardware Test
	LCD Test
	Z-axis Calibration
	Z-Offset Setting
08	04 Prepare Your 3D File
08	05 File Import & Internet Connection
10	06 Printing Test

01 Before You Start

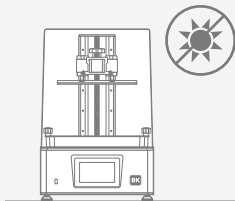

Stable Printing Environment

Store your 3D printer in a dry and ventilated environment. Avoid exposure to direct sunlight. Make sure to place the printer on a flat surface.

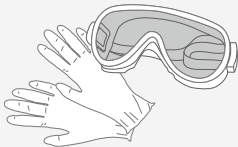

Protective Measures

While printing and using resin, please make sure to wear gloves, masks, protective goggles, and long-sleeved clothing.

Maintenance

Clean the Z-axis

First, dry clean the Z-axis T-screw. Then apply a thin layer of general lubricant to it, so that it rotates smoothly.

Clean the 3D Printer

Use 95% alcohol and tissue paper to carefully clean the printer, the resin vat, and the building plate.

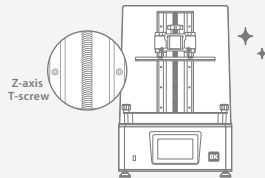

02 Introduction

Printer Parts

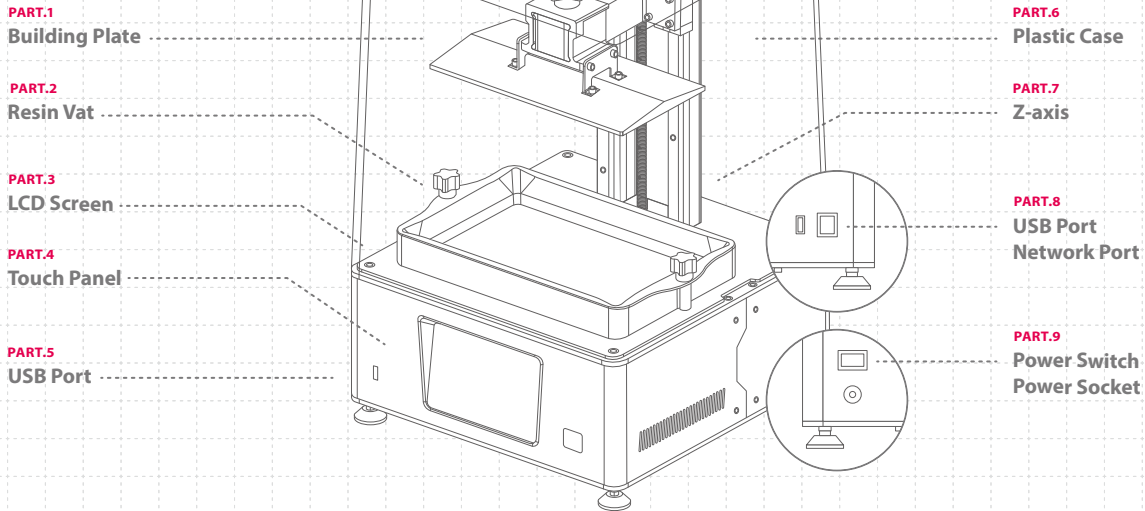

The Toolbox



After Sales Service Card



Gloves



Power Adapter



Plastic Funnel



Scrapers



Allen Wrench



USB



Wi-Fi Adapter

Operation

System	Phrozen OS
Operation	5 inch Touch Panel
Slicer Software	CHITUBOX V2.0
Connectivity	USB Ethernet Wi-Fi

Printing Specifications

Technology	Resin 3D Printer - LCD Type
Light Source	Linear Projection LED Module
XY Resolution	28 μ m
Layer Thickness	0.01-0.30 mm
Max Printing Speed	70 mm / hr
Power Requirement	24 VDC;5A

Hardware Specifications

Printer Size	L33.7 x W33.7 x H51.6 cm
Printing Volume	L21.8 x W12.3 x H23.5 cm
Printer Weight	14.3 kg

* All specifications have been tested in a laboratory. Please note that certain specifications may be subject to change without prior notice.

03 Prepare Your 3D Printer

Guided Process for Initial Use

Follow the guides on the touch screen during initial use to complete the LCD test, Z-axis calibration, and test printing (XP_finder.stl file) in order to confirm the relevant settings of the printer. If you missed the guided process, you can set it up by following the steps in the manual.

Hardware Test

It is recommended to perform the hardware test when printing for the first time by following the steps below:

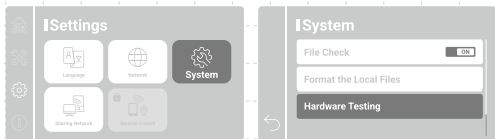

Operate the left column and switch to the "Settings" page > click "System" > Swipe down and click "Hardware Testing."

The test contents include:

- 1 Light cooling fan switch test.**
- 2 LCD test:** Please refer to the "LCD Test."
- 3 Z-axis running test:**
Press and hold the key all the way to the bottom to confirm that the building plate moves normally.
- 4 Z-axis sensor detection:**
When the building plate reaches the bottom, the light display will turn green.
- 5 Printer firmware version.**

LCD Test

- 1** Remove the resin vat and wear anti-UV goggles to avoid eye injury.
- 2** Test the "LIGHT UP, LCD GRID, and BLACKEND" modes one after another to make sure the LCD screen displays the same images as shown on the touch panel. The test will run for 30 seconds in each mode.
- 3** When the LCD screen fully displays the three modes. The LCD Test is completed.

Z-axis Calibration

- 1 Notice! The other Z-axis control could NOT be turned on, if the Z-axis calibration was not executed during initial use.
- 2 Use the following steps to calibrate your Z-axis:
Click "Tools" > click "Z-axis Control" > click "Z-axis Calibration."



- 3 Follow the instructions on the screen to execute Z-axis calibration:
 - Remove the resin vat. Place an A4 paper on the LCD screen.
 - Loosen the four screws on both sides of the building plate.
 - Wait until the building plate touches the LCD screen.
 - Then tighten all four screws.
 - Click "DONE" to finish calibration. Wait until the building plate retracts to the TOP.

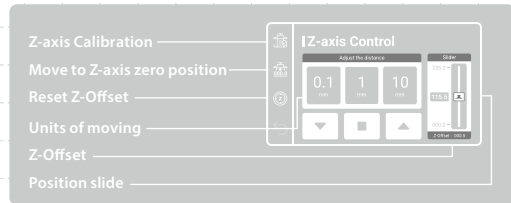

Z-Offset Setting

After calibrating the Z-axis, you can use this function to modify your Z-offset position when needed. You may also use this function if you want to print flat on the building plate or if the resin flow is slow.

- 1 For initial use, please perform Z-axis calibration first.
- 2 Click "Move to Zaxis zero position."
- 3 We recommend to use 0.1mm setting as an elevating unit to fine-tune the position.
- 4 After confirming the position, click "Reset Z-Offset" to complete the setting.

IMPORTANT NOTICE: After resetting or rebooting the hardware, please reconfirm the Z-offset distance before printing.

04 Prepare Your 3D File

- 1 We provided the "Phrozen_Test_Rook" and "Phrozen_XP_Finder" 3D models and the print files in the USB for print testing; the STL editable files and CTB print files are included for both of them.
- 2 The STL files require the use of slicing software (such as CHITUBOX) to convert them into CTB files for printing.
- 3 If the Aqua-Gray 8K resin is used, the CTB print file provided can be used directly to print.
- 4 Use a computer to import your STL file into the slicing software, add the "Sonic Mighty 8K" printer, and set the print parameters according to the resin used.
- 5 Once the setting is complete, slice the 3D file and import it as a CTB file and place it on the USB drive, and the file preparation is complete.



Slicing Software



Resin Parameters



Learn & Download
Phrozen_XP_Finder

05 File Import & Internet Connection

Sonic Mighty 8K can transfer files through USB drive and internet connection. The printer has 3.5GB of built-in memory, able to save transferred files.

Import Files Through USB

- 1 Use CHITUBOX to slice the printing file, save it as a CTB file onto the USB drive, and insert the USB drive into the printer.
- 2 Perform the following operations on the touch panel in the "Print" page: Click the "USB" > select file > "PRINT;"

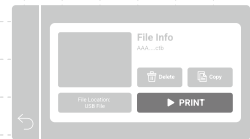

Connecting The Printer to a Computer

1 Select the internet connection method

Use the USB wireless network card included in the accessory box to connect to Wi-Fi, or insert the network cable and connect through Ethernet.

2 Connecting to the internet

Enter the "Settings" page, click "Network," and select "Wi-Fi" or "LAN Cable" on the side.



3 Confirm the printer IP

Return to the "Settings" page > Click "Sharing Network" > Enable the setting. The IP address is at the bottom-most field.

4 Connecting the printer to a computer

Have the computer connect to the same local area network as the printer, and enter the printer IP number into the empty folder location.

*The username and password have to be entered manually for initial use.

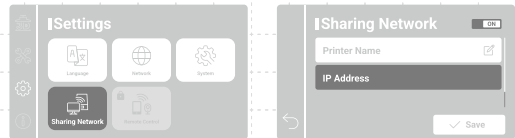

06 Printing Test

- 1 Use Aqua-Gray 8K resin and the "Phrozen_XP_Finder" model CTB file to perform testing.
- 2 Install the building plate and resin vat. Confirm that both are clean with no foreign objects.
- 3 Shake the resin evenly and pour it into the resin tank. Do not exceed the "MAX" mark on the resin tank when pouring.

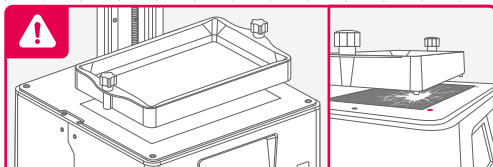

NOTICE: When installing the resin vat, please make sure the bottom screws of the resin vat are perfectly aligned with the platform grooves, then tighten the screws on both sides. Please pay attention to the bottom screws when placing the resin vat, and **DO NOT** damage the LCD screen.

- 4 Insert the USB drive or select the "Phrozen_XP_Finder_AQ8K.ctb" file in the printer and click "Print."
- 5 Keep the plastic case closed during printing to prevent excessive UV light exposure.
- 6 Once printing is complete, remove the building plate from the printer. Then tilt, place the building plate onto a table and use the metal scraper to carefully remove your print.
- 7 Use 95% alcohol or Phrozen Wash Resin Cleaner to rinse your printed model, Then cure your models with a post-curing chamber; after curing, your first print is complete.

After-sales service & warranty

- Phrozen offers a one-year warranty for all parts, excluding consumable components such as the LCD screen and PFA(nFEP) film.
- Sonic Mighty 8K LCD screen is covered under a 3-month warranty. Please note that this warranty does not cover any damages caused by human factors.
- If you encounter any difficulties, please scan the QR code to contact us.

Contact us!



Congratulations!

You have just completed your first run.
We hope you've had a great experience!

Please follow Phrozen's social media accounts
and subscribe to our YouTube channel to learn
more about printing tips and share information
with the community.



Facebook



Facebook Group

Sonic Mighty 8K



YouTube



Instagram